



Monaco de Trois-Rivières 2010

**Supplementary Regulations** amended July 19th  
VEGA Cup #3 and ECKC RACE 5 - July 23, 24, 25, 2010  
Monaco de Trois-Rivières, Trois-Rivières, Québec

**Categories of Competition:**

- Rotax DD2
- Rotax DD2 Master
- Rotax Master
- Rotax Max Senior
- Rotax Max Junior
- Rotax Mini-Max
- Rotax Micro-Max
- Pro Shifters
- Honda Master
- Honda Senior
- Honda Junior



On-Line Registration for Round 3 hosted by Monaco de Trois-Rivières is available at <http://www.eckc.ca/registration>

**NOTE #1: Please notice changes to Rotax Mini Max gear ratios and carburetion specifications.**

**NOTE #2: Paypal payments not-allowed will lead to automatic disqualification.**

**NOTE #3: Official hotel: Hotel Delta, 1620, Notre-Dame, Trois-Rivières, 1-800-268-1133**

**www.deltahotels.com** This hotel is about 5 minutes walk from the track and we negotiated a special price for July 23-24, 2010. A premier room with breakfast included is \$139 plus tax. Mention that you are taking part in the Monaco when you make your reservation. Guests have access to an indoor pool and fitness center. Indoor and outdoor parking are available at the hotel (\$).

**L'Urbania : 3600 Boulevard Gene-H Kruger, Trois-Rivières, 819-379-3232.** This hotel is about 2 minutes in car from the track.



## Contents

1.	Sanctioning .....	3
2.	Event Organizers and Event Inquires .....	3
3.	The Track.....	3
4.	Sportsmanship Theme .....	3
5.	Registration Fees.....	4
6.	Eligible Entries and Licence Requirements.....	4
7.	Practice Days Fee .....	5
8.	Tires to Be Used .....	5
9.	Event Officials.....	5
10.	Regulations and Precedence of Regulations .....	5
11.	Changes to Regulations.....	6
12.	Masters Rotax .....	6
13.	Micro Max .....	6
14.	Mini Max.....	6
15.	Honda.....	6
16.	Class Structure .....	7
17.	Rotax Micro MAX and Rotax Mini MAX .....	7
18.	Tire, Oil Specifications .....	8
19.	Paddock Spaces .....	9
20.	Restricted Areas .....	9
21.	Driver Briefings.....	9
22.	Number of Karts on the Race Track .....	9
23.	Qualifying Procedures .....	9
24.	Transponders.....	9
25.	Transponder Mounting Location .....	10
26.	Marking of Engines and Tires .....	10
27.	Official Notice Board .....	10
28.	Fuel and Oil .....	10
29.	Foreign Driver and Rotax Max Engine Eligibility .....	11



## 5. Registration Fees

---

Rotax Class Registration Rotax DD2 (Masters), Rotax Senior, Rotax Junior, Mini-Max, Rotax Master Includes 1 driver pass, 1 mechanic pass, trailer parking (20X20)	\$125.00
Pro Shifters Includes 1 driver pass, 1 mechanic pass, trailer parking (20X20)	\$125.00
Micro-Max and Honda Class Registration Honda Masters, Honda Senior, Honda Junior, Micro-Max Includes 1 driver pass, 1 mechanic pass, trailer parking (20X20)	\$100.00
Transponder rental (drivers may provide their own transponders)	\$15.00
Saturday controlled practice ( July 24th)	\$35.00
Friday controlled practice (July 23th)	\$25.00

---

**Your kart number will not be reserved until registration payment is complete.**

## 6. Eligible Entries and Licence Requirements

Residents of Canada – Canadian residents must be members in good standing of any ASN Canada FIA affiliated kart club. They may enter any ECKC Class provided they possess the appropriate license, their kart and equipment meets the appropriate technical requirements, and the driver meets the entry qualifications for their particular class.

Residents of the USA – USA residents are eligible for all ECKC classes provided that they present a valid kart club racing license. USA residents must pay a \$20.00 (CDN) associate member fee.

**NOTE: Only permanent residents of Canada are eligible to qualify for the Rotax classes at the 2010 ASN Canada FIA Canadian Karting Championships**

All participants (parents or guardian must sign for participants under 18) and crew members must read and sign a waiver form. No participant will be allowed to go on track until they have registered for the event. Participants under 18 years of age, unaccompanied by parents or guardians must produce a fully completed copy of the ASN Annual Parental Consent Waiver. Forms are available at [www.asncanada.com](http://www.asncanada.com).

All karts must have the appropriate kart sticker before entering the track.

Registration fees must be paid at the track the day of the event, until registration ends. Upon completion of all paper work and the payment of all fees, documentation and passes will be given to the participants.

**N.B. When registering at the track, the racing fees are payable by cash or cheque only.**

If a cheque is discovered to be without found upon cashing, it will be deemed that the driver did not take part to the race and his results will be erased.

Accreditation will take place at the track on: Friday from 2:00 PM to 8:00 PM and Saturday from 7:30 AM to 11:30 AM. Everyone admitted to the site (officials, organizers, sponsors, medias) must sign a waiver.

**PLEASE NOTICE THAT EACH TENT MUST HAVE A 5 LBS MINIMUM FIRE EXTINGUISHER ON HAND. OR ELSE YOU WON'T BE ALLOWED TO SET UP YOUR TENT.**

## 7. Practice Days Fee

The fee for the official Friday July 23, 2010 practices is 25.00\$.

The fee for the official Saturday July 24, 2010 practice is \$35.00.

Drivers will be entitled to trial runs on Saturday from 8:30 a.m. to 3:00 p.m. Qualifications will be in 8 minutes increments at 3:30 p.m. All drivers who want to take part in the qualification session must be registered and have handed in their technical inspection sheet before heading onto the track or else he will be subject to a penalty. All classes will have a 5 minute trial run on Sunday morning before their pre-final. If there are more than 34 registrations for a class, 2 qualifications sessions will be done and only the best 34 drivers will take part to the pre-final and final. The last session of practice before the qualification will be timed to be able to divide the group.

## 8. Tires to Be Used

Tires – All participants that want to use new tires for the event are required to purchase them at the Monaco organization stand. All tires have to be branded excepted rain tires. Participants can provide their own rain tires and/or practice tires. **Tire vouchers** will be **sold** at registration. **Tires** will be available for **pick up** Saturday before qualifications.

**Only dry tires branded by the organization will be authorized. For all classes: all new dry tires have to be bought at the event at regular retail price. Used tires have to be branded by the organization.**

## 9. Event Officials

Registration:	Club de Karting de l'Est du Québec (CKEQ)
Race director:	Érick Baker
Assistant director:	Bill Oakman
Race steward:	Denys Beaudin
Assistant race steward:	Stéphane Roy
Technical inspector:	Pierre Laberge
Assistant technical inspector:	Don Moormeister
Race starter and flaggers:	ASRQ
Timing and scoring:	Club de Karting de l'Est du Québec (CKEQ)

## 10. Regulations and Precedence of Regulations

The event will be run in accordance with the Karting Quebec regulation (see [www.kartingquebec.ca](http://www.kartingquebec.ca)), the 2010 ASN Canada FIA Canadian Karting Regulations; Book 1- Sporting Regulations and Book 2- Technical Regulations (available at [www.asncanada.com](http://www.asncanada.com)) and the Rotax Max Challenge Regulations (RMC - available at [www.maxchallenge.ca](http://www.maxchallenge.ca)).

The regulations shall be as follows (in order of precedence):

- a) Karting Québec's security, sports and technical regulations; "Règlements de sécurité, sportifs et technique de Karting Québec"
- b) Karting Québec's bulletins
- c) 2010 ASN Canada FIA Canadian Karting Regulations
- d) ASN's bulletins
- e) This supplementary regulation
- f) Official bulletins issued before and during the event
- g) Instructions from approved officials

Any claim of lack of knowledge of the regulations will not be entertained.

## **11. Changes to Regulations**

This supplementary regulation can only be amended or changed by the Eastern Canadian Karting Championship or the VEGA Cup organizers and by the event steward as necessary. The schedule of track sessions and races may be adjusted by the event organizers and officials.

## **12. Masters Rotax**

The rules for the class MASTER allow the engine ROTAX only.

Class eligibility: Any driver aged 32 years and over. Drivers under 32 years old weighing 190 lbs and more with their equipment except the headset will be allowed to participate in the class. The verification process should be made after each official release on the track. The driver under 32 years doing 190 lbs and more will be weighed without his kart. Once this check done, he will be weighed with his kart and must meet the weight class regulations.

## **13. Micro Max**

Rims and weight have to comply with the Karting Quebec's regulation.

## **14. Mini Max**

The rear bumper has to be in plastic. The overall rear track has to be: 134 cm minimum and 136 cm maximum.

## **15. Honda**

In the Honda classes, a clutch shoe is obligatory. The overall rear track has to be: 119 cm minimum and 127 cm maximum.

## 16. Class Structure

Class	Grade	Age	Engine Rules	Weight (Kg)	Weight (Lbs)
Rotax DD2	B	15 years old and more	RMC	173	381
Rotax DD2 Master	C	32 years old and more	RMC	180	396
Rotax Master	C	32 years old and more	RMC	174.6	385
Rotax Max Senior	B	15 years old and more	RMC	165	364
Rotax Max Junior	C	12 to 16 years old	RMC	145	320
Rotax Mini-Max	C	10 to 14 years old	RMC	131.5	290
Rotax Micro-Max	C	8 to 10 years old	RMC	106.5	235
Pro Shifters	B	15 years old and more	ASN	184	405
Honda Senior	C	15 years old and more	ASN	149.7	335
Honda Junior	C	9 to 15 years old	ASN	127	290
Honda Master	C	30 years old and more	ASN	165.5	365

## 17. Rotax Micro MAX and Rotax Mini MAX

Gear Ratio and Carburetor Set-ups. The following specifications are mandatory for the Monaco de Trois-Rivières.

### Rotax Micro MAX

**Gear Ratio:**

Front sprocket: 14

Rear sprocket: 73

**Carburetion:**

Needle: K98

Combination 2

Main Jet: 125

### Rotax Mini MAX

**Gear Ratio:**

Front sprocket: 13

Rear sprocket: 82

**Carburetion:**

Needle: K98

Combination 1

Main Jet: 155

## 18. Tire, Oil Specifications

Class	Type	Tire	Model	Front Size	Rear Size	Oil	Fuel
Rotax DD2	Dry	MOJO	D3	10x4.50-5	11x7.10-5	According CIK 2010	Super unleaded
	Rain	MOJO	W2	10x4.20-5	11x6.00-5		
Rotax DD2 Master	Dry	MOJO	D3	10x4.50-5	11x7.10-5	According CIK 2010	Super unleaded
	Rain	MOJO	W2	10x4.20-5	11x6.00-5		
Rotax Master	Dry	VEGA	NORD-AM	10x4.60-5	11x7.10-5	According CIK 2010	Super unleaded
	Rain	VEGA	W5	10x4.20-5	11x6.00-5		
Rotax Max Senior	Dry	MOJO	D2	10x4.50-5	11x7.10-5	According CIK 2010	Super unleaded
	Rain	MOJO	W2	10x4.20-5	11x6.00-5		
Rotax Max Junior	Dry	MOJO	D2	10x4.50-5.00	11x7.10-5	According CIK 2010	Super unleaded
	Rain	MOJO	W2	10x4.20-5	11x6.00-5		
Rotax Mini-Max	Dry	VEGA	NORD-AM	10x4.60-5	11x6.50-5	According CIK 2010	Super unleaded
	Rain	VEGA	W5	10x4.20-5	11x6.00-5		
Rotax Micro-Max	Dry	VEGA	NORD-AM	10x4.60-5	10 x 4.60-5	According CIK 2010	Super unleaded
	Rain	VEGA	W5	10x4.20-5	10x4.20-5		
Pro Shifter	Dry	VEGA	FM	10x4.60-5	11x7.10-5	According CIK 2010	OPEN
	Rain	VEGA	W5	10x4.2-5-5	11x6.00-5		
Honda Senior	Dry	VEGA	NORD-AM	10x4.60-5	11x6.50-5	OPEN	Regular
	Rain	VEGA	W5	10x4.20-5	11x6.00-5		
Honda Junior	Dry	VEGA	NORD-AM	10x4.60-5	11x6.50-5	OPEN	Regular
	Rain	VEGA	W5	10x4.20-5	11x6.00-5		
Honda Master	Dry	VEGA	NORD-AM	10x4.60-5	11x6.50-5	OPEN	Regular
	Rain	VEGA	W5	10x4.20-5	11x6.00-5		

**WET TIRES:** Participants acquire specified wet tires from their own sources. The quantity of WET tires may be adjusted in a future event bulletin depending on weather and track conditions.

### Rotax Max Classes:

RMC regulations apply.

DRY: One set of four DRY tires for the ENTIRE round (Saturday and Sunday).

WET: One set of four WET tires for the ENTIRE round (Saturday and Sunday).

### Canada Junior and Canada Senior:

DRY: One set of four DRY tires for the ENTIRE round (Saturday and Sunday).

WET: One set of four WET tires for the ENTIRE round (Saturday and Sunday).

### Rotax Mini MAX and Rotax Micro MAX:

DRY: One set of four DRY tires for the ENTIRE round (Saturday and Sunday).

WET: One set of four WET tires for the ENTIRE round (Saturday and Sunday).

## 19. Paddock Spaces

Contact ECKC (Stéphanie Bergeron) by email at [info@ckeque.com](mailto:info@ckeque.com) or by phone at 819-377-5566 ext: 248.

Drivers may begin entering the paddock at **noon on Thursday, July 22th**. A spot will be assigned to each driver. Drivers may remain within their assigned area and keeping it clean, which includes picking up trashes. Trashes must be disposed according to environmental standards (paper and food in the garbage cans, toxic liquid such as oil and gas in the provided containers). **Every driver must have a 5 lbs minimum fire extinguisher on hand.** Anyone who does not keep his spot clean may be forbidden from registering to a subsequent event.

All personal vehicles, trailers and motor homes must be parked in the indicated area outside of the paddocks.

## 20. Restricted Areas

The racetrack field, the perimeter of the track, the pit lane, pre-grid, grid, scale area and technical inspection areas are restricted areas.

Access to the grid and pit lane is available only to participants when their class is running. One crewmember with a mechanic's pass is allowed on the grid with each entry.

## 21. Driver Briefings

Drivers must attend the driver briefing.

## 22. Number of Karts on the Race Track

ASN Canadian Karting Regulations Book 1, Regulation 10.3.

A maximum of 34 karts will be allowed to start in pre-final and in final. The event organizer and officials may alter this number.

## 23. Qualifying Procedures

ASN Canadian Karting Regulations Book 1, Regulation 11.3. Qualifying for a Race.

For qualifying sessions, drivers will enter the track from pre-grid only on a first-come, first-served basis. A driver can join their designated qualifying session at any time prior to the checkered flag. Drivers must exit the track only through the designated weighing area. A driver may not leave the track and enter the pits, paddock or grid and return during a qualifying session. If a driver stops for any reason during a qualifying session the driver will be allowed one attempt to try and start again with or without assistance from race officials. A driver may not receive assistance from anyone other than an official of the event.

## 24. Transponders

Each kart must be equipped with a transponder mounting bracket. Transponders are available for a rental fee of \$15.00. Drivers who wish to rent a transponder must indicate this on their entry form.

## 25. Transponder Mounting Location

The competitor is responsible for securing the scoring transponder to the kart to prevent loss of the transponder. The transponder must be mounted on the center of the rear of the driver seat. The location must be 25 cm (+/- 5 cm) from ground level. Minor offset from the center of the seat is permitted.

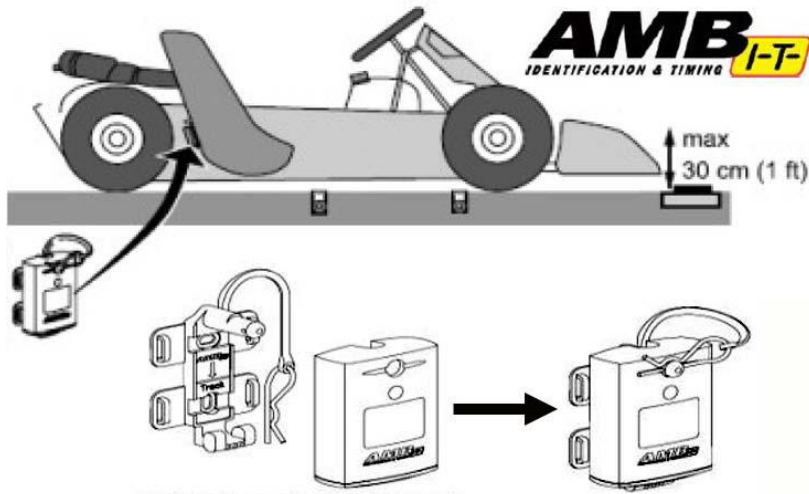

## 26. Marking of Engines and Tires

Engines and tires will be marked either before qualification sessions. It is the driver's responsibility to be sure that their engines and tires are marked before leaving the scale area.

## 27. Official Notice Board

The official notice board is located near the grid.

## 28. Fuel and Oil

Fuel used by the participants must comply with the environmental regulations and respect the chart at the #18 item of this supplementary regulation. The legal fuel has to come from the Irving station at 330 rue St-Roch (near the Hotel Delta).

**IT'S STRICTLY FORBIDDEN TO SPILL OIL OR GAS ON THE ASPHALT, BECAUSE IT'S NEW. IN A CASE OF AN ACCIDENT, PLEASE ABSORB IT RIGHT AWAY. IT'S YOUR RESPONSIBILITY TO PROTECT THE ASPHALT UNDER YOUR WORKING AREA.**

## **29. Foreign Driver and Rotax Max Engine Eligibility**

A foreign driver can race at the Monaco de Trois-Rivières with his engines on the following conditions:

1. His engine was introduced in his country by an authorized Rotax distributor
2. His engine must be sealed by a Canadian authorized service centre with a Canadian seal number and must be sealed according to the Rotax Max Challenge rules in force.
3. In case of a technical DQ for an illegal engine, the foreign driver will not be authorized to register to any future Monaco events.